

Please read and save these instructions. Read through this owner's manual carefully before using product. Protect yourself and others by observing all safety information, warnings, and cautions. Failure to comply with instructions could result in personal injury and/or damage to product or property. Please retain instructions for future reference.



20V MAX* LI-ION CORDLESS ANGLE GRINDER

FOR CUSTOMER SERVICE

Technical Question?

CALL 1-866-458-2472
customerservice@oem-tools.com

UNPACKING

After unpacking unit, inspect carefully for any damage that may have occurred during transit. Check for loose, missing, or damaged parts. If any damage is observed, a shipping damage claim must be filed with carrier. DO NOT use the OEMTOOLS® Cordless Angle Grinder if broken, bent, cracked or damaged parts (including labels) are noted. Any Cordless Angle Grinder that appears damaged in any way, operates abnormally or is missing parts should be removed from service immediately. If you suspect that the Cordless Angle Grinder was subjected to shock load (a load that was dropped suddenly, unexpectedly, etc.) immediately discontinue use until it has been checked by a factory authorized service center.



*Voltage is measured without workload. Maximum initial battery voltage after charging. Nominal voltage is 18 Volts.

⚠ WARNING

The following safety information is provided as a guideline to help you operate your Cordless Angle Grinder under the safest possible conditions. Any tool or piece of equipment can be potentially dangerous to use when safety or safe handling instructions are not known or not followed. The following safety instructions are to provide the user with the information necessary for safe use and operation. Please read and retain these instructions for the continued safe use of your service system. Failure to follow instructions listed below may result in serious injury. In addition, make certain that anyone who uses the equipment understands and follows these safety instructions as well.

Explanation of Safety Signal Words

⚠ WARNING: Indicates a potentially hazardous situation which, if not avoided, could result in death or serious injury.

⚠ CAUTION: Indicates a potentially hazardous situation which, if not avoided, may result in minor or moderate injury.

CAUTION: Used without the safety alert symbol indicates a potentially hazardous situation which, if not avoided, may result in property damage.

NOTES: Provide clarity and helpful information.

Thank you very much for choosing an OEMTOOLS® Product!

For future reference, please register your new tool at www.oem-tools.com and complete the owner's record below:

Model: _____ **Purchase Date:** _____

Save the receipt, warranty and these instructions. It is important that you read the entire manual to become familiar with this product before you begin using it. This product is designed for certain applications only. OEMTOOLS® cannot be responsible for issues arising from modification. We strongly recommend this product is not modified and/or used for any application other than that for which it was designed. If you have any questions relative to a particular application, DO NOT use the product until you have first contacted customer service to determine if it can or should be performed on the product.

⚠ WARNING: This product can expose you to chemicals, including acrylonitrile, which are known to the State of California to cause cancer and birth defects or other reproductive harm. For more information, go to www.P65Warnings.ca.gov.



20V MAX* LI-ION CORDLESS ANGLE GRINDER

POWER TOOL SAFETY

Read and understand all safety warnings and instructions. Failure to follow the warnings and instructions may result in electric shock, fire and/or serious injury.

Save all warnings and instructions for future reference.

WORK AREA SAFETY

1. Keep work area clean and well lit. Cluttered or dark areas invite accidents.
2. DO NOT operate power tools in explosive atmospheres, such as in the presence of flammable liquids, gases or dust. Power tools create sparks which may ignite the dust or fumes.
3. Keep children and bystanders away while operating a power tool. Distractions can cause you to lose control.

ELECTRICAL SAFETY

1. Double insulated tools are equipped with a polarized plug (one blade is wider than the other). This plug will fit in a polarized plug only one way.
2. If the plug does not fit fully into the outlet, reverse the plug. If it still does not fit, contact a qualified electrician to install a polarized outlet. DO NOT alter the plug in any way. Double insulation eliminates the need for the three-prong grounded power cord and grounded power supply system.
3. Avoid body contact with grounded surfaces such as pipes, radiators, ranges and refrigerators. There is increased risk of electric shock if your body is grounded.
4. DO NOT expose power tools to rain or wet conditions. Water entering the power tool will increase the risk of electric shock.
5. DO NOT abuse the cord. Never use the cord to carry the tool or pull the plug from an outlet. Keep cord away from heat, oil, sharp edges or moving parts. Replace damaged cords immediately. Damaged cords increase the risk of electric shock.
6. When operating a power tool outdoors, use an outdoor extension cord marked "W-A" or "W". These cords are rated for outdoor use and reduce the risk of electric shock.

PERSONAL SAFETY

1. Stay alert, watch what you are doing and use common sense when operating a power tool. DO NOT use a power tool while you are tired or under the influence of drugs, alcohol or medication. A moment of inattention while operating power tools may result in serious personal injury.

2. Dress properly. DO NOT wear loose clothing or jewelry.
3. Contain long hair. Keep hair, clothing, and gloves away from moving parts. Loose clothing, jewelry, or long hair can get caught in moving parts.
4. Avoid accidental start-ups. Verify that the switch is in the OFF position before plugging in the tool. Carrying a power tool with a finger on the switch or plugging in a tool that has the switch in the ON position invites accidents.
5. Remove adjusting keys and wrenches before turning the tool ON. A wrench or key that is left attached to a rotating part of the tool may result in personal injury.
6. DO NOT overreach. Keep proper footing and balance at all times. Proper footing and balance allows the operator to maintain better control of the tool in unexpected situations.
7. Use safety equipment. Always wear eye protection.
8. Use a dust mask, non-skid safety shoes, a hardhat, or hearing protection when appropriate.

POWER TOOL SAFETY

1. Use clamps or another practical means to secure and support the workpiece to a stable platform. Holding the work in a hand or against the body is not stable, and may lead to loss of control.
2. DO NOT force the tool. Use the correct tool for the application. The correct tool will do the job better and safer when used at the rate that it was designed to work at.
3. DO NOT use a power tool if it cannot be turned ON or OFF using the power switch. A tool that cannot be controlled using the switch is dangerous, and must be repaired.
4. Disconnect the plug from the outlet before making any adjustments, changing accessories, or storing the tool. Such preventive safety measures reduce the risk of accidental start-ups.
5. When power tools are not in use, store them out of the reach of children or untrained persons. Tools are dangerous in the hands of untrained users.
6. Maintain tools with care. Keep cutting tools sharp and clean. Properly maintained cutting tools with sharp cutting edges are less likely to bind, and are easier to control.
7. Inspect the tool for misalignment or binding of moving parts, broken parts, and any other condition that may affect the operation of the tool. If it is damaged, have the tool serviced before using it. Many accidents are caused by poorly maintained tools.



20V MAX* LI-ION CORDLESS ANGLE GRINDER

- Use only accessories that are recommended by the manufacturer for this model. Accessories that are suitable for one tool may become hazardous when used with another tool.

SERVICE

Tool servicing must be performed by qualified personnel. Service or maintenance performed by non-qualified personnel could result in a risk of injury.

When servicing a tool, use only identical replacement parts. Follow the instructions in the Maintenance section of this Manual. The use of unauthorized parts or failure to follow the instructions in the Maintenance section of this Manual may create a risk of electric shock or injury.

SPECIFIC SAFETY RULES

WARNING

- Know your cordless angle grinder. DO NOT plug in the charger or install a battery in the tool until you have read and understood this Instruction Manual. Learn the tool's applications and limitations, as well as the specific potential hazards related to this tool. Following this rule will reduce the risk of electric shock, fire, or serious injury.
-  Always wear eye protection. Any power tool can throw foreign objects into your eyes and cause permanent eye damage. ALWAYS wear safety goggles (not glasses) that comply with ANSI safety standard Z87.1. Everyday glasses have only impact resistant lenses. They ARE NOT safety glasses.
- Glasses or goggles not in compliance with ANSI Z87.1 could cause serious injury when they break.
- Always wear gloves to protect your hands from hot sparks.
- Always wear hearing protection and a dust mask. Use only in well ventilated areas. Use of personal protective equipment and working in a safe environment will reduce the risk of injury.
- Always keep hands out of the path of the grinding disc. Avoid awkward hand positions where a sudden slip could cause your hand to move into the rotating disc.
- To avoid injury from accidental starting, always remove the battery from the angle grinder before installing or removing grinding discs.
- The grinding disc and guard must be securely attached as described in this Owner's Manual before installing a battery in the tool. Failure to do so will increase the risk of serious injury if the grinding disc shatters.
- Make sure the guard is in good condition and securely installed before operating grinder.

- Secure the workpiece. Use clamps or a vise to hold the work when practical. It's safer than using your hand and it frees both hands to operate the tool.
- DO NOT clamp grinder in vise or use as a fixed grinder.
- Grinding discs must be stored in a dry location to prevent deterioration.
- Before attaching the grinding disc, inspect it for visible defects. If it is cracked, chipped or warped do not install it.
- Use only grinding discs in compliance with ANSI Standard B7.1 and rated for a speed greater than 11,000 RPM.
- DO NOT remove the soft paper in the center of the grinding disc.

NOTE: If this paper has been previously removed, insert some soft rubber or paper between the grinding disc and the disc flange to prevent damage to the grinding disc.

- DO NOT alter or enlarge the center hole of the grinding disc as this could result in breaking it.
- DO NOT over tighten the clamp nut on the grinding disc. Excessive tightening may cause the disc to crack and possibly shatter during operation.
- DO NOT use the grinder if the disc flange or clamp nut is missing or if the spindle is bent.
- Check to make sure and any extension cords are clear of the area to be cut. Contact with "live" wires could shock the operator or cause a fire.
- Always hold the grinder securely with two hands while working and at all times when it is running.
- Never turn the grinder ON with the grinding disc or any rotating parts touching the work surface
- Never cover the air vents in the motor housing with your hands while operating the grinder.

IMPORTANT SAFETY INSTRUCTIONS

The warnings, precautions, and instructions discussed in this manual cannot cover all possible conditions and situations that may occur. The operator must understand that common sense and caution are factors which cannot be built into this product, but must be supplied by the operator.

WARNING

Use only attachments recommended or sold by manufacturer.

- DO NOT disassemble the cordless angle grinder. Take it to a qualified professional when service or repair is required. Incorrect reassembly may result in electric shock or fire.
- Wear approved safety eye/face shield, ear defenders and hand protection.



20V MAX* LI-ION CORDLESS ANGLE GRINDER

DISPOSAL

At the end of the useful life of the OEMTOOLS® 20V MAX* Li-Ion Cordless Angle Grinder, dispose of the components according to all state, federal and local regulations.

BATTERY DISPOSAL

Exposure to high temperatures can cause the batteries to explode; do not dispose of in a fire. Some countries have regulations concerning battery disposal. Follow all applicable regulations. Return used batteries to a collection location for recycling. Call 800-822-8837 or visit www.call2recycle.org to find a collection location.

PURPOSE

The OEMTOOLS® 20V Max Li-Ion Cordless Angle Grinder delivers 10,000 RPM for the most demanding applications including grinding, polishing, cutting and sanding.

PRODUCT SPECIFICATIONS

| | |
|----------------------|--------------|
| Voltage: | 20V MAX* |
| Speed: | 10,000 RPM |
| Max. Disc Diameter: | 4-1/2" |
| Spindle Thread: | 5/8" |
| Spindle Lock: | Yes |
| Min. Disc Thickness: | 1/4" |
| Weight: | 7.97 Lbs. |
| Battery: | 4.0Ah Li-Ion |
| Charge Time: | 2 Hrs. |

INSTRUCTIONS

ASSEMBLY AND OPERATION

⚠ WARNING

Always disconnect your angle grinder from the power source when replacing grinding or cut-off discs, adjusting the guard, cleaning the tool or when the tool is not in use. Disconnecting the angle grinder will prevent accidental starting that could cause serious personal injury.

INSTALLING THE AUXILIARY HANDLE

1. Unplug the angle grinder from the power source.
2. Install the auxiliary handle (1) by screwing it clockwise into the left side (2) of the gear housing (3) (Fig. 1).

NOTE: The handle can be installed in two different positions; left side or right side (Fig. 3 and 4).

⚠ WARNING

The auxiliary handle must always be used to prevent loss of control and possible injury.

3. Tighten the auxiliary handle securely.

NOTE: Hand tighten the auxiliary handle. DO NOT over tighten.

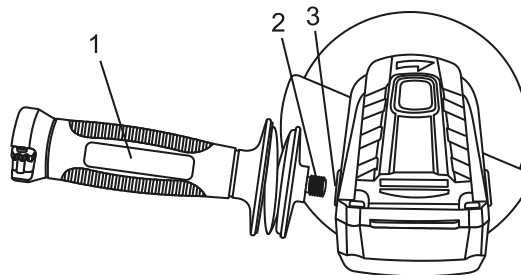

Fig. 1

INSTALLING THE GUARD

⚠ WARNING

The guard must be installed before installing a grinding disc or using the angle grinder. Failure to do so could result in serious personal injury.

1. Pull the guard clamp lever (1) outward to allow the guard clamp (2) to expand for installation.
2. Slide the guard clamp (2) over the spindle housing (3) until the blade guard locating detents (4) mate with the grooves (5) in the spindle housing (Fig. 2).

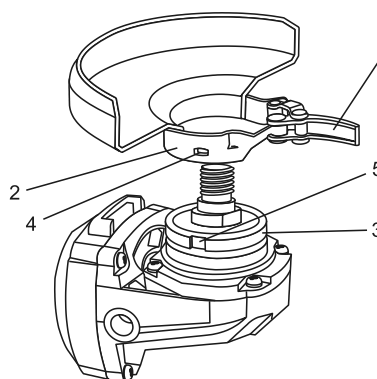

Fig. 2

3. Press the guard clamp fully onto the spindle housing.

NOTE: Rotate the guard so it is positioned correctly depending upon the location of the side handle in Fig. 3 and 4.

4. Push the guard clamp lever toward the guard clamp until the guard clamp firmly locks the guard onto the spindle housing.



20V MAX* LI-ION CORDLESS ANGLE GRINDER

POSITIONING THE GUARD

⚠ WARNING

The guard must be positioned correctly to protect the operator. Guard placement depends upon which side of the tool the auxiliary handle is used, to afford the greatest protection for the user. Rotate the guard to the correct position as noted in Fig. 3 or 4 below.

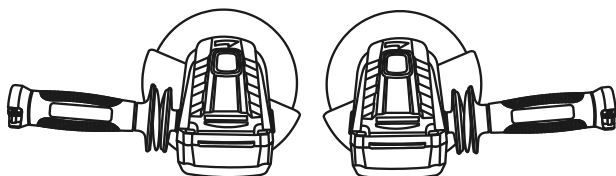

Fig. 3 and 4

CHANGING A GRINDING DISC

⚠ WARNING

Use the correct size grinding disc. Never use a grinding disc thinner than 5/32" (3.9 mm).

⚠ WARNING

Never use a grinding disc with a rated speed of less than (11,000 RPM). A grinding disc with a rated speed of less than 11,000 RPM can break and fly apart.

1. Lock the disc guard onto the spindle housing.
2. Depress the spindle lock button (1) and rotate the grinding disc (2) until the spindle locks (Fig. 5).

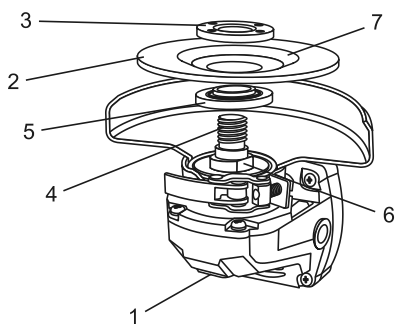

Fig. 5

3. Grasp the grinding disc and rotate the grinding disc in a counterclockwise direction. Once the grinding disc and outer disc flange (3) are loose, continue to turn the outer disc flange counterclockwise by hand until it is removed from the spindle (4).
4. Remove the grinding disc from the spindle

NOTE: If the outer flange cannot be loosened by hand, use the wrench provided. DO NOT remove the inner disc flange (5).

5. Make sure the flats on the inner disc flange are engaged with the flats on the spindle (6).

6. Place the grinding disc over the spindle with the concave side of the disc (7) facing outward.

7. Screw the outer disc flange onto the spindle with the flat side of nut facing away from the grinding disc. Tighten to finger tight only.

NOTE: Make sure the raised small diameter portion of both the inner and outer disc flanges are fitted into the hole in the grinding disc.

8. Depress the spindle lock button and rotate the grinding disc clockwise until the spindle locks.
9. Grasp the grinding disc and turn it clockwise to securely tighten the grinding disc and outer flange onto the spindle.

NOTE: You may also tighten the grinding disc and outer flange onto the spindle using the wrench provided.

⚠ WARNING

Never attach a wood cutting or carving blade of any type to this angle grinder. It is designed for grinding metal only. Use for any other purpose is not recommended and creates a hazard which will result in serious injury.

⚠ WARNING

Never cover the air vents. They must always be open for proper motor cooling.

ON/OFF SWITCH AND LOCK-ON BUTTON

1. To turn the switch ON, pull the lock-off toggle back and then squeeze the switch lever. To turn the switch OFF, release the switch lever.
2. To activate the lock-on switch while the angle grinder is running, press the lock-on button. While holding the lock-on button inward, release the ON/OFF switch. The angle grinder will continue to run.
3. To turn the angle grinder OFF, squeeze and release the ON/OFF switch.

⚠ WARNING

When turning the angle grinder OFF, always wait until the grinding disc comes to a complete stop before setting the tool down.

GRINDING

1. Always select and use grinding discs that are recommended for the material to be ground. Make sure that the maximum operating speed of the grinding disc selected is not less than 11,000 RPM.
2. Secure all work before beginning the grinding operation.
3. Secure small workpieces in a vise or clamp to a work bench.



20V MAX* LI-ION CORDLESS ANGLE GRINDER

⚠ WARNING

Never use your angle grinder with the guard removed. It has been designed for use only with the guard installed. Attempting to use the angle grinder with the guard removed will result in loose particles being thrown against the operator resulting in serious personal injury.

⚠ WARNING

Never use your angle grinder without eye protection. Following this rule will reduce the risk of serious personal injury.

- The efficient operation of the angle grinder begins by controlling the pressure and surface contact between the grinding disc and the workpiece. Flat surfaces are ground at an acute angle, normally between 5° and 15° (Fig. 6).

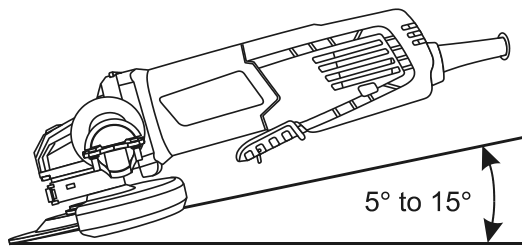

Fig. 6

- For maximum control, hold the angle grinder in front and away from you with both hands, keeping the grinding disc clear of the workpiece. Start your angle grinder and let the motor and grinding disc build up to full speed. Gradually lower the angle grinder until the grinding disc contacts the workpiece.
- For best results keep the angle grinder tilted at an angle of between 5° and 15° degrees and continuously moving at a steady, consistent pace. Move the angle grinder back and forth or up and down over the work area. Keep the angle grinder moving so that an excessive amount of material is not removed from one area. If the angle grinder is held in one spot too long, it will gouge and cut grooves in the workpiece. If the angle grinder is held at too sharp an angle, it will gouge the workpiece because of the concentration of pressure on a small area.

CHARGING THE BATTERY PACK:

- Place the charger in a dry location near a 120V/60 Hz electrical outlet.
- Plug the charger into the electrical outlet.
- The green LED light will turn on.
- Turn the battery pack upside down and slide it onto the charger.
- The green LED light will turn off and the red LED light will begin to flash indicating the battery pack is charging.
- The red LED light will turn off and the green LED light will turn on when fully charged.
- Once the battery pack is fully charged, remove the charger plug from the power source and remove the battery pack from the charger.

NOTE: DO NOT charge batteries when the work area or the battery temperature is at or below 32° F (0° C) or above 113° F (45° C).

| Green Light | Red Light | Battery on the Charger | Charging Status |
|-------------|-----------|------------------------|-------------------------------------------|
| ON | OFF | NO | Charger connected to power supply |
| OFF | FLASHING | YES | Battery charging |
| ON | OFF | YES | Battery fully charged |
| OFF | ON | YES | Battery defective or bad contact |
| ON | ON | YES | Battery too hot or too cold to be charged |



20V MAX* LI-ION CORDLESS ANGLE GRINDER

NOTE:

Not all components of the Cordless Angle Grinder are replacement items, but are illustrated as a convenient reference for location and position in the assembly sequence.

Parts List

| Figure | Description | Qty. |
|--------|------------------------|------|
| A | Outside Flange | 1 |
| B | Grinding Wheel | 1 |
| C | Rubber Ring | 1 |
| D | Inner Flange | 1 |
| E | 115 mm Wheel Guard | 1 |
| F | Output Spindle | 1 |
| G | Dust Proof Ring | 1 |
| H | Screw | 4 |
| I | Spring Washer | 4 |
| J | Gear Cover | 1 |
| K | Bearing | 1 |
| L | C-Clip | 1 |
| M | Big Gear | 1 |
| N | Needle Bearing | 1 |
| O | C-Clip | 1 |
| P | Screw | 4 |
| Q | Gear Housing | 1 |
| R | Spindle Lock Spring | 1 |
| S | Spindle Lock Button | 1 |
| T | Needle Bearing | 1 |
| U | Pinion | 1 |
| V | O-Ring | 1 |
| W | Bearing | 1 |
| X | Bearing Clamp | 1 |
| Y | Screw | 1 |
| Z | Joint Shaft | 1 |
| AA | Rubber Tray | 1 |
| BB | Screw | 2 |
| CC | Joint Tray | 1 |
| DD | Fan | 1 |
| EE | Air Deflector | 1 |
| FF | Screw | 2 |
| GG | Spring Washer | 2 |
| HH | Motor Flange | 1 |
| II | Motor | 1 |
| JJ | Lock-Off Button Spring | 1 |
| KK | Cotter Pin | 1 |
| LL | Lock-Off Button | 1 |
| MM | Switch Button | 1 |
| NN | Switch | 1 |
| OO | Magnetic Ring | 1 |
| PP | Pole Plate | 1 |
| QQ | Battery | 1 |
| RR | Housing | 1 |
| SS | Screw | 6 |
| TT | Handle | 1 |
| UU | Ring | 1 |
| VV | Spanner Holder | 1 |
| WW | Spanner | 1 |

Parts Diagram

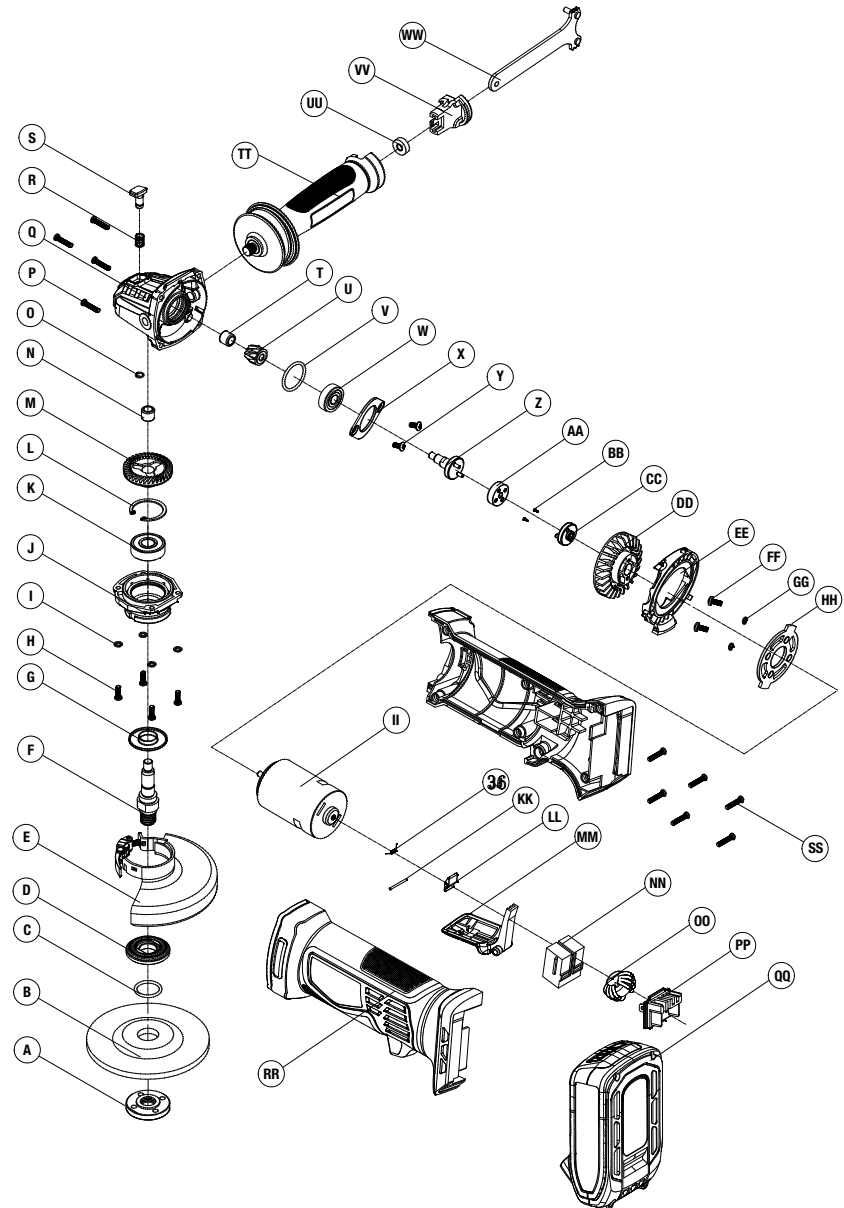

Don't forget to register your new OEMTOOLS® product at www.oem-tools.com.



This symbol designates that this tool is listed with Intertek 3042597 U.S. requirements by ETL Testing Laboratories, Inc. JG5972. Conforms to UL Std. 60745-1 and 60745-2-2.





20V MAX* LI-ION CORDLESS ANGLE GRINDER

OEMTOOLS® ONE YEAR WARRANTY

If for up to one year from the date of purchase of this OEMTOOLS® product you find any defect in material or workmanship, through normal usage, return it to the place of purchase, or to OEMTOOLS® for repair or replacement at our discretion. In order to obtain this service, send your tool and proof of purchase, transportation pre-paid, to OEMTOOLS® Q.A. Dept., 3580 E. Raines Road #3, Memphis, TN 38118. We will not be responsible for lost or damaged goods during transportation; please insure your package. If our inspection verifies the defect, we will either repair or replace the product at our election, or we may elect to refund the purchase price if we cannot readily and quickly provide you with a replacement. We will return repaired products at our expense, but if we determine there is no defect, or that the defect resulted from causes not within the scope of our warranty, then you must bear the cost of returning the product.

OEMTOOLS® does not provide warranty for products labeled other than OEM® or OEMTOOLS®. OEMTOOLS® will not provide any warranty for products subjected to abnormal use. Abnormal use includes, but is not limited to, abuse, accident, alteration, neglect, and unauthorized or unreasonable use or repairs. This warranty does not cover bits, blades, files, batteries, or calibration. We recommend that you maintain your tools and sharpen or replace blades, bits, files, and batteries as necessary. OEMTOOLS® reserves the right to make any changes in construction or design at any time without any obligation in incorporating such changes to tools or equipment previously sold.

OEMTOOLS® makes every effort to ensure that its products meet high quality and durability standards, and warrants to the original purchaser that this product is free from defects in materials and workmanship for the period of one year from the date of purchase. This warranty does not apply to damage due directly or indirectly to misuse, abuse, negligence or accidents, repairs or alterations outside our facilities, criminal activity, improper installation, normal wear and tear or to lack of maintenance.

We shall in no event be liable for death, injuries to persons or property, or for incidental, contingent, special or consequential damages arising from the use of our product. Some states do not allow the exclusion or limitation of incidental or consequential damages, so the above limitation of exclusion may not apply to you. THIS WARRANTY IS EXPRESSLY IN LIEU OF ALL OTHER WARRANTIES, EXPRESS OR IMPLIED, INCLUDING THE WARRANTIES OF MERCHANTABILITY AND FITNESS. This warranty gives you specific legal rights, and you may also have other rights, which vary from state to state.

CONTACT US

3580 E. Raines Road, Suite 3, Memphis, TN 38118
Tel: 1-866-458-2472
www.oem-tools.com