

OEM TOOLS®

30-inch 4 Drawer Service Cart

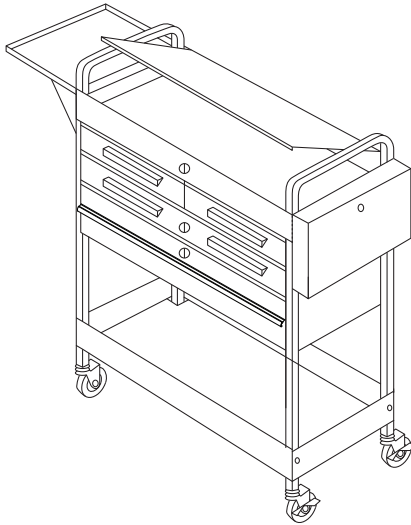

204JGT005BLK
24962

CAUTION:

1. Read and follow all safety information and instructions before using this product for the first time.
2. Fill in the following information and retain the manual for future reference:

Model #:

Place of purchase:

Date of purchase:

Receipt # of purchase:

PLEASE NOTE: When requesting warranty service please call: 1-866-458-2472 (8:00 a.m. to 5:00 p.m., CST) and have the model number, cash register receipt and the date of purchase available when you call. DO NOT SHIP YOUR PRODUCT BACK TO THE STORE, OR TO US, UNLESS WE SEND YOU WRITTEN INSTRUCTIONS FOR RETURN.

CAUTION: TAKE SAFETY PRECAUTIONS WHEN USING YOUR SERVICE CART



Do not open more than one drawer at a time.



Do not step or lean on the drawers.



Do not let children near the service cart.



Set the brake on the locking casters unless you are moving the service cart.



Lock drawers before moving the service cart.

SAFETY

SAFETY

WARNING: READ ALL SAFETY INSTRUCTIONS BEFORE ASSEMBLING AND USING THIS PRODUCT.

- **WEAR SAFETY GLASSES AND GLOVES** when assembling this product.
- **DO NOT** stand on this product. You may fall, which may cause personal injury.
- **DO NOT** alter this product in any manner. For example, do not weld external lock bars or attach electrical equipment to it. This may cause product damage or personal injury.
- **BE CAREFUL** of sharp edges.
- Keep the product on a level surface. The product may become unstable and tip if stored or moved on a tilted surface, and may cause personal injury or product damage.
- The maximum weight for each loaded drawer of the cabinet should be no more than 100 lb (45 kg).
- **ALWAYS WEAR ANSI-approved safety goggles** when working with tools and equipment.

PARTS LIST

FOR SERVICE REGARDING PARTS, ASSEMBLY OR WARRANTY INFORMATION,
PLEASE CALL OUR CUSTOMER SERVICE NUMBER: 1-866-458-2472 (8:00 A.M. TO 5:00 P.M., CST)

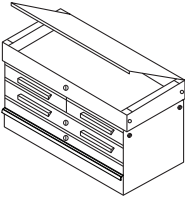

Locking Drawer Assembly

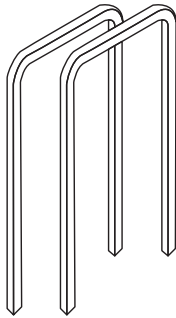

Chrome Legs (2)
(with inserts installed)

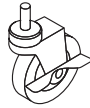

Locking Casters (2)

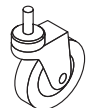
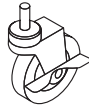

Non-Locking Casters (2)

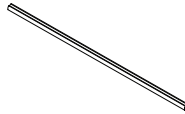

Long Drawer Handle (1)



Short Drawer Handle (1)

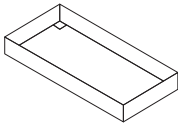

Bottom tray



10 mm Bolts,
Washers and Nuts
(8 pcs. each)



14 mm Bolts,
Washers and Nuts
(8 pcs. each)



Drawer Handle Screws (12)



Keys (attached to legs)

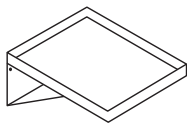

Side Work Bench

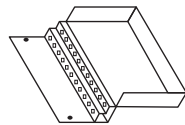

Pry Bar Holder

TOOLS REQUIRED FOR ASSEMBLY

- Rubber mallet
- 10 mm wrench
- Phillips screwdriver
- Table or workbench
- 2 People

ASSEMBLY

NOTE: DO NOT FULLY TIGHTEN FASTENERS UNTIL PROMPTED.

STEP 1: Assembly preparation

Clear table top and set locking drawer assembly on table top, with lid facing up. Position the locking drawer assembly so that one end hangs off the table enough to allow the chrome legs to go through the square holes. Insert one set of chrome legs through the overlapping holes as shown in Figure 1. Do not bolt legs to top.

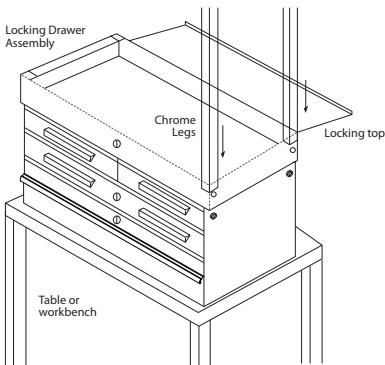

Tighten bolts until parts fit together firmly.

REPEAT STEPS 1 AND 2 FOR OTHER END OF CART, USING REMAINING SIDE ACCESSORY.

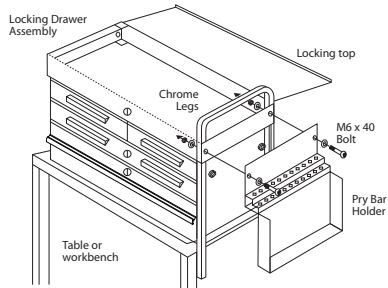

STEP 3: Connect the bottom tray to the chrome legs

Lift the cart and place on top of the bottom tray with chrome legs through the square leg-holes. Align bolt holes in bottom tray with lower holes in legs and insert a 10 mm bolt through the washer, bolt holes and legs as shown. Repeat with all remaining holes in bottom tray.

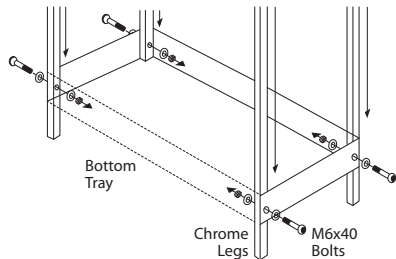

STEP 2: Connect legs and side accessory to drawer assembly

Choose one of the side accessories (pry bar holder or side work bench – Figure 2 shows pry bar holder) for attachment to the overhanging end of the service cart. Align the outermost bolt holes in the accessory with the bolt holes in the end of the cart and with the uppermost holes in the chrome legs. Position a washer and insert a 10 mm bolt through the washer, bolt holes and legs as shown. Secure bolts with a flat washer, lock washer and nut on inside of locking drawer assembly.

ASSEMBLY

STEP 4

IMPORTANT: Tighten all bolts

AT THIS POINT, ALL BOLTS SHOULD BE TIGHTENED. TIGHTEN BOLTS OPPOSITE EACH OTHER RATHER THAN TIGHTENING ALL BOLTS ON ONE SIDE FIRST SO THAT THE CART REMAINS ALIGNED. AVOID USING EXCESSIVE FORCE WHEN TIGHTENING BOLTS. OVER-TIGHTENING BOLTS CAN MAKE DRAWERS BIND AND HINDER OPERATION.

STEP 5

Attach handles to drawer faces

Open the bottom drawer of the service cart. Align the end of the long handle with the edges of the bottom drawer, so that the channel in the handle covers all four holes in the front of the drawer. Insert screws through each hole from inside the drawer and into the drawer handle channel. Tighten the screws. Repeat for all remaining drawers using short handles.

NOTE: DO NOT ALLOW HANDLES TO OVER HANG THE ENDS OF THE DRAWER FACES, AS THEY WILL INTERFERE WITH THE OPERATION OF THE DRAWER.

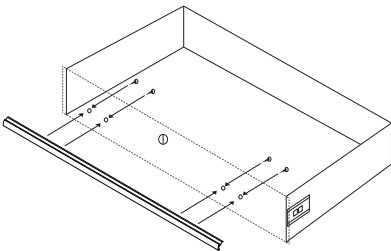

STEP 6

Attach casters

With the provided keys, lock all drawers, the top and the pry bar holder to prevent them from opening. Turn the cart upside down, allowing it to rest on chrome leg tops with the plastic inserts facing up.

NOTE: DO NOT ALLOW THE SIDE WORK BENCH TO SWING FREELY, AS IT MAY BE DAMAGED OR CAUSE INJURY AS CART IS TURNED UPSIDE DOWN.

Insert the stem of one caster into the hole in a plastic insert. Using a rubber mallet, hammer the casters into place until the stem is no longer visible. Repeat with other casters.

NOTE: MAKE SURE BOTH LOCKING CASTERS ARE EITHER ON THE RIGHT HAND SIDE OR LEFT HAND SIDE OF THE CART.

Once all casters are installed, stand the cart upright. Assembly is complete.

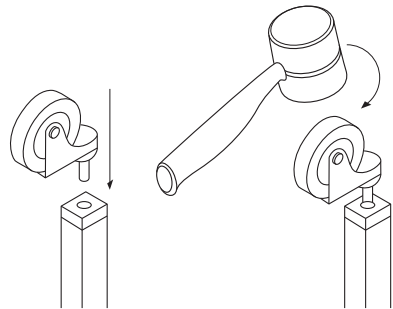

OPERATION

RAISE AND RELEASE DRAWER FRONTS:

This unit is equipped with the raise and release drawer fronts. To open, lift up on the drawer front while pulling towards you. To close, shut the drawer firmly until the latch engages. If the drawer does not stay closed, the hook may be bent, or it may rub against the drawer slides. To fix this problem, lightly bend the hook until the drawer will engage in the slide.

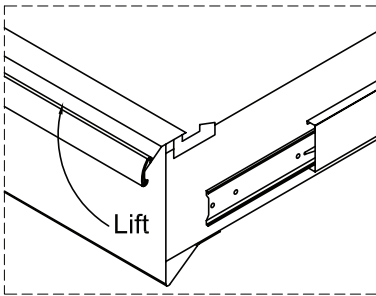

TO REMOVE DRAWERS

Empty drawer. Pull drawer out to almost full extension.

Push up on right hand black release lever, while pulling down on the left hand black release lever. While holding the levers in the positions as instructed above, pull the drawer outward until it is released from the drawer slide.

PUSH UP
(RIGHT HAND SIDE)

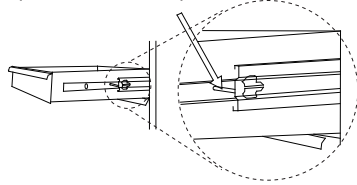

PULL DOWN
(LEFT HAND SIDE)

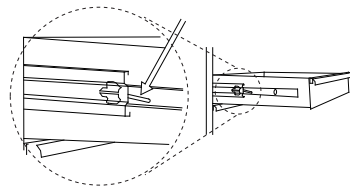

TO REPLACE DRAWERS

Empty drawer. Extend the drawer slides from the tool chest. Insert the brackets on each side of the drawer into the slots in the cabinet slides, being careful that they are properly positioned. Once properly inserted, completely close the drawer to set the slides in their proper positions.

REPLACEMENT PARTS

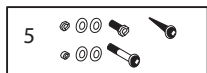
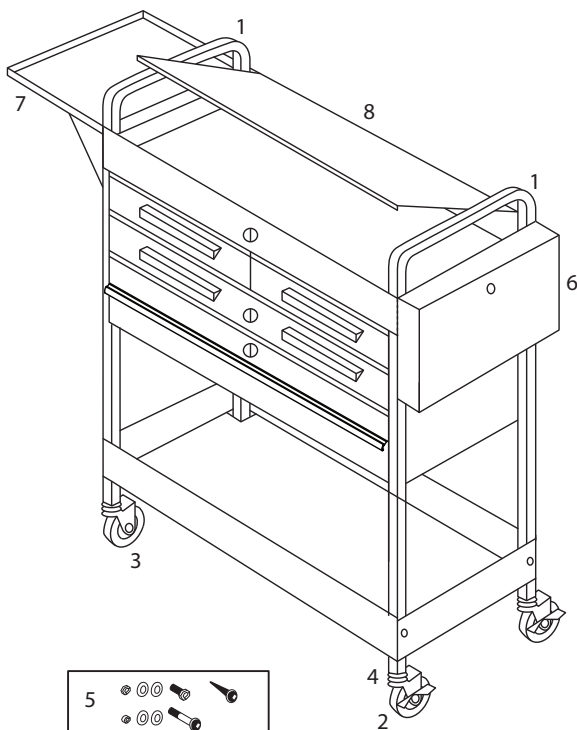

ITEM	PART #	REQ'D QTY	DESCRIPTION
1	*	2	CHROME LEG/EA.
2	RSSCPLW	2	LOCKING CASTER/EA.
3	RSSCPW	2	NON-LOCKING CASTER/EA.
4	RSSCPP1	1	SET OF 4 PLASTIC INSERTS
5	RS8013ADLXBK	1	BOLT KIT (INCL. 8 EA. OF 10 MM AND 14 MM BOLTS, NUTS, WASHERS AND 4 SCREWS)
6	8011BK	1	PRY BAR HOLDER
7	8004BK	1	SIDE WORK STATION
8	8002BK	1	TOP LID

*For replacement, purchase RSSC7, Chrome Leg, and 8014, Leg Extensions.

ALSO AVAILABLE	
RS3DHDLB	SHORT BLACK DRAWER HANDLE
RS8006HDLB	LONG BLACK DRAWER HANDLE
RS8006HDLS	HANDLE SCREWS (SET OF 4)
RSRBSLIDEC2	CLIP-ON ROLLER BEARING SLIDE/PR.
8006CRBBK	BLACK REPLACEMENT LARGE DRAWER
8016BK	BLACK REPLACEMENT 3 DRAWER UNIT
8007BK	BLACK REPLACEMENT THIRD SHELF
8013LS	4-PIECE LOCK & KEY SET, KEYED ALIKE
1110	EVA FOAM FOR TRAYS/10 PK.
1111	EVA FOAM FOR DRAWERS/10 PK.
8004SSM	RUBBER LINER FOR SIDE SHELF/10 PK.

FOR SERVICE REGARDING PARTS, ASSEMBLY OR WARRANTY INFORMATION, PLEASE CALL OUR CUSTOMER SERVICE NUMBER: 1-866-458-2472 (8:00 A.M. TO 5:00 P.M., CST)

WARRANTY

WARRANTY

The service cart is warranted to be free from defects in materials and workmanship for a period of one (1) year from the date of original purchase. If this product is defective, please call 1-866-458-2472 (8:00 a.m. to 5:00 p.m., CST). If the product is defective, we will replace the defective part at no cost to you. Please do not ship your product back to the store or to us unless we send you written instructions for return. In the event it becomes necessary for your product to be returned, we will notify you how to proceed. A copy of your original purchase receipt must accompany the returned product.

WARRANTY CLAIM PROCEDURE

If a claimable defect occurs, please fill out a claim form through our website at: www.qualitycraft.com or contact our customer service department at 1-866-458-2472 (8:00 a.m. to 5:00 p.m., CST).

Before you make your claim call, please make sure you have:

1. The description of the service cart
2. Proof of sale
3. Details regarding the defect
4. Name and address of the owner.

Claims must be filled out in writing and returned within six (6) months of appearance of defect. Failure to comply with this stipulation will make the warranty null and void. We reserve the right to a thirty-day (30) delay following receipt of claim in which to inspect the product. We assume no responsibility for labor costs or removing/replacing a previously installed product or transportation or return of a product.

IMPORTED BY

Great Neck Saw
1-866-458-2472

Made in China